

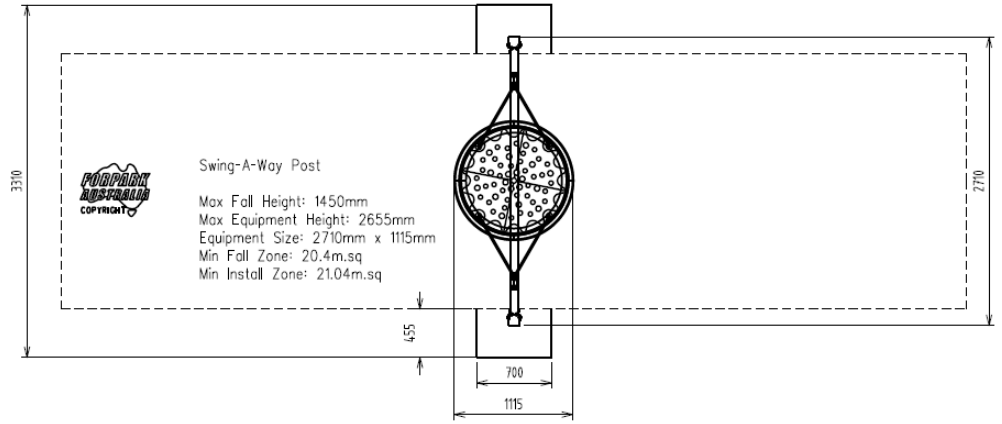

SWING-A-WAY POST SPECIFICATION SHEET

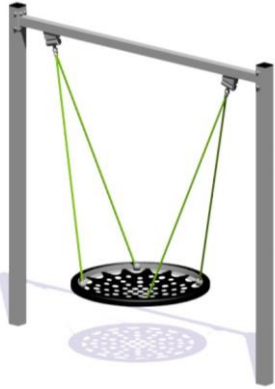

FALL ZONES

Area: 20.4m² | FHOF: 1.45m | Equip Size: 2.71m width | Max Height: 2.655m

PRODUCT CODE	SW128
COLOURS	Frame: Standard Powdercoat Range Rope: Standard Rope Colours
MATERIAL SPECIFICATION	Uprights: Galvanised Steel Top Bar: Galvanised Steel Fasteners: Steel & stainless steel Basket: Ali/Rubber or Rope Powder Coating: 80-120µ
AGE GROUP	All Ages
PLAYSPACES	Parks, schools, commercial



[DOWNLOAD DESIGN FILES HERE](#)



OTHER INFORMATION

Spare Parts: Available | Warranty: 20 years | Quality Assurance: Yes | Insurance: Yes
 Installation: Refer manual

STANDARDS

Complies with relevant Australian Standards including:
 • AS 4685:2014 (P 1-6) | • AS 4685.0:2017 | • AS/NZS 4422:2016

*All information is commercial in confidence and is the property of Forpark Australia. All information in correct as at September 2018.

*For details regarding Australian Standards, Warranties, Insurances, QA and Installation please contact your local office.