

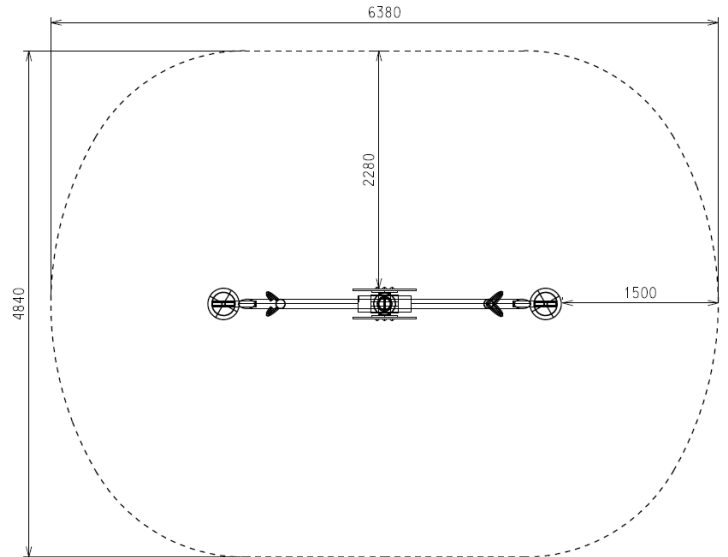

# Gravitator

## SPECIFICATION SHEET



### FALL ZONES

Area: 4.84m x 6.38m (27.2m<sup>2</sup>) | FHO: 1.2m | Equip Size: 3.4m | Max Height: 2m

PRODUCT CODE	FS48
COLOURS	Frame: Standard Powdercoat Range Seats: Standard Plastic Range Disk: Blue/Red
MATERIAL SPECIFICATION	Frame: Galvanised Steel Fasteners: Steel & Stainless Steel Powder Coating: 80-120u Plastic: Injection Moulded/Tri Laminate
AGE GROUP	4-12 years
PLAYSPACES	Parks, schools, commercial



[DOWNLOAD DESIGN FILES HERE](#)



### OTHER INFORMATION

Spare Parts: Available | Warranty: 20 years | Quality Assurance: Yes | Insurance: Yes  
Installation: Refer manual

### STANDARDS

Complies with relevant Australian Standards including:  
• AS 4685:2014 (P 1-6) | • AS 4685.0:2017 | • AS/NZS 4422:2016

\*All information is commercial in confidence and is the property of Forpark Australia. All information is correct as at September 2017.

\*For details regarding Australian Standards, Warranties, Insurances, QA and Installation please contact your local office.