



## FLYING/GLIDING FOX MAINTENANCE

The Flying/Gliding Fox are large pieces of play equipment that require specific maintenance regimes to keep them performing in a fun and safe manner. To ensure the equipment remains this way Forpark Australia recommends that the following steps are followed.

Along with the general inspections, detailed in the Forpark Australia Safety and Maintenance schedule, the Flying/Gliding Fox cable tension needs to be checked at the following intervals; 2 weeks after install, 6 weeks after install and then at 3 month intervals thereafter. The design of the Flying/Gliding Fox places a high amount of load on the cable. To allow the cable to accept this level of load the cable will stretch during the first 6 to 18 months of use.

To allow the easy checking of cable tension it is important that some measurements are obtained before the Flying/Gliding Fox are opened to the public. Start by placing the pommel/seat frame at a point roughly  $\frac{3}{4}$  the way down the cable. Take a measurement from the bottom of the pommel/seat frame to ground level. Be aware that ground level (the natural level around the Flying/Gliding Fox) and soft fall level (sand, mulch, bark etc.) are not the same thing. Soft fall levels can rise and fall and as such it is not recommended that measurements from the soft fall are used to ascertain cable stretch. Once a method of measuring the pommel and seat frame levels is established then this same method must be used whenever cable stretch is being measured.

Forpark recommends a minimum of 450mm and max of 700mm between the bottom of the seat and finished soft fall level. More information is available in the installation instructions which can be obtained through your local Forpark Australia branch or on the website.

To tension the cable firstly remove the 13mm bolt from the cable adjuster. Insert the tension bar (supplied with the original installation) into the round hole and turn. Teeth on cog will click into place.

Once desired tension is achieved replace bolt and tighten. To assist with tensioning it is advisable to prop up the cable at the mid-point, taking away some of the weight of the cable.

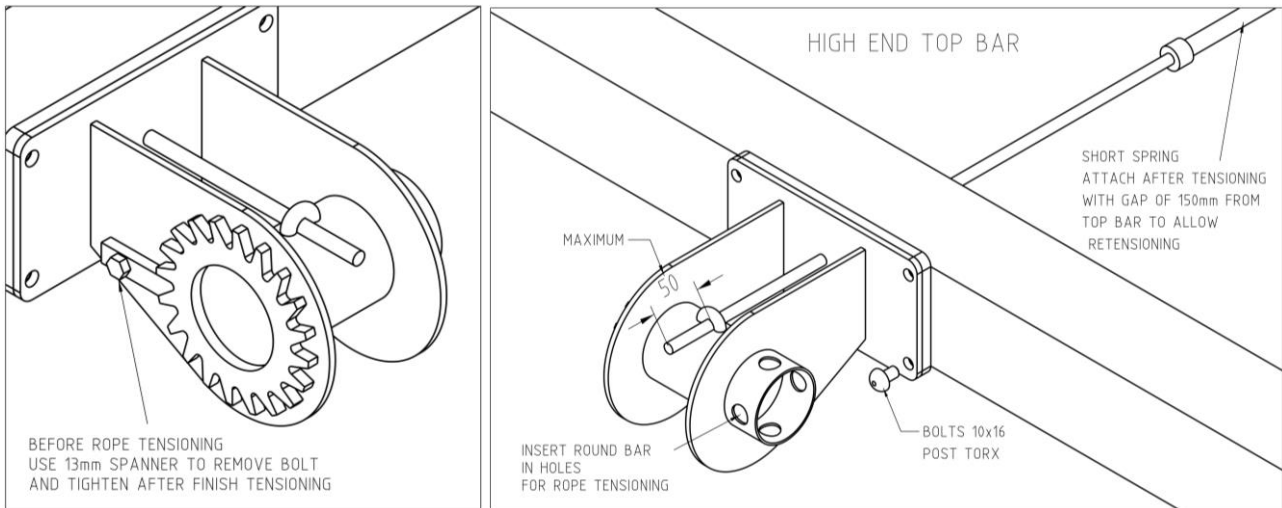

It is important to not over tension the cable and or tension when not required. The playground standard allows a minimum clearance from seat bottom to finished soft fall level of 400mm and a maximum of 1900mm.

Note: if the soft fall level has fallen significantly and the fall distance from the pommel and seat frame to the soft fall is higher than 700mm it is acceptable to loosen the cable tension to lower the pommel and or seat until the soft fall can be replenished.

In addition to cable tensioning, all chain links, d-shackles, s-hooks and chain attaching hardware should be inspected regularly (on a 3 monthly basis). In particular the chain links that are the closest to the Flying/Gliding Fox trolley should be inspected for excessive wear. To adequately inspect these links you will need to remove the bolt and nut (using two 13mm spanners) that is used to attach the chain to the trolley. Once this bolt is removed you can inspect the links for signs of excessive wear.

If excessive wear is found it is advised that you remove the two top links (using a portable grinder or bolt cutters) and fit a new attaching bolt that is available through your local Forpark Office. The original chain could be trimmed (two links at a time) on two or three occasions before a new piece of chain will need to be ordered.

**Note: These instructions are intended as a guide. All maintenance works should be carried out by a suitably qualified person. Please call your local Forpark office if you would like any further advice.**